

免费拿样，联系电话/微信：18666128282

REV	DESCRIPTION	DATE
A/0	原始版本	
A/1	修订版本	

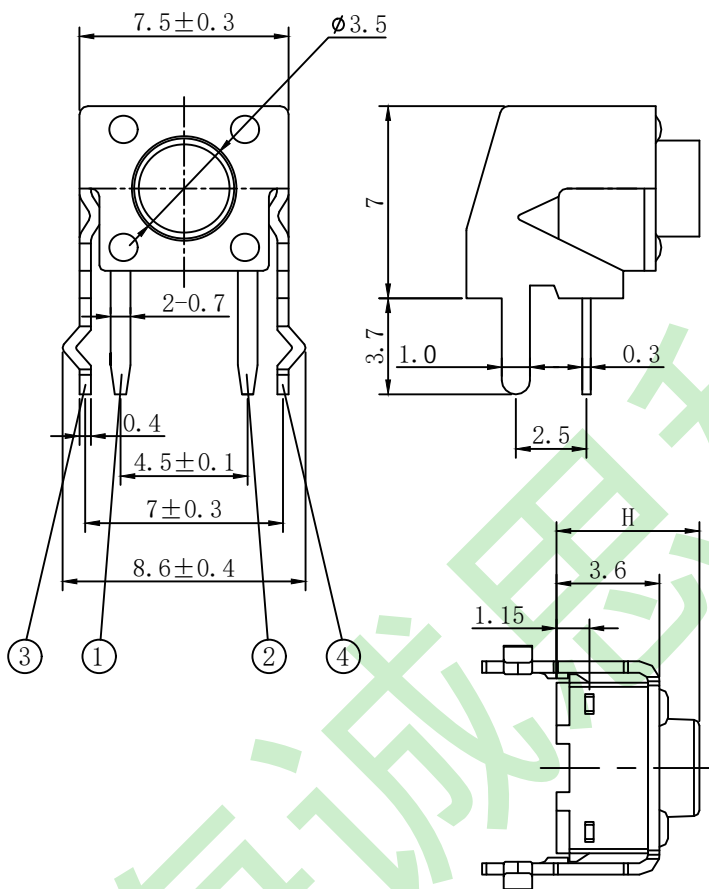
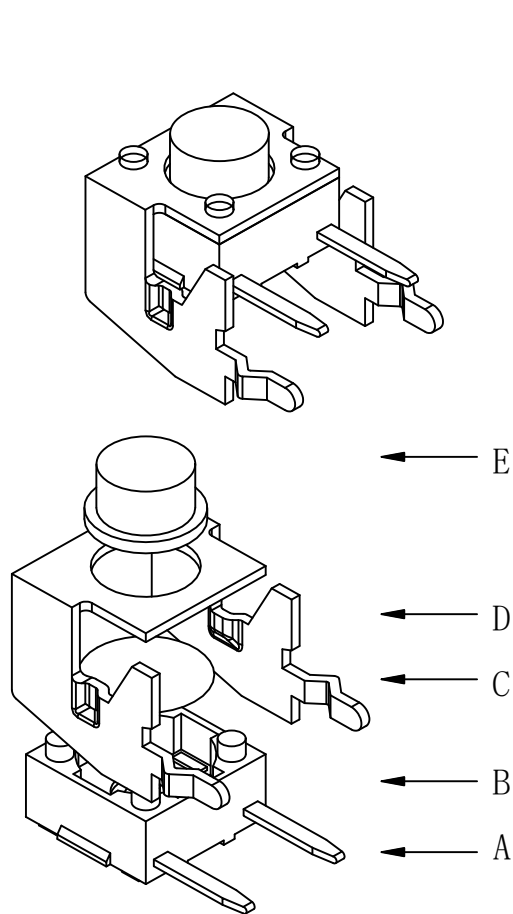

H	
4.3	4.5
5.0	5.5
6.0	6.5
7.0	7.5
8.0	8.5
9.0	9.5

规格参数:

额定电流 Rate current: 50mA
 额定电压 Rate voltage: DC 12V
 接触电阻 Contact resistance: $\leq 100\text{m}\Omega$
 操作力 Operating force: $250 \pm 40\text{gf}$ (可选)
 行程 Travel: $0.25 \pm 0.1\text{mm}$
 绝缘电阻 Insulated resistance: $\geq 100\text{M}\Omega$
 介电强度 Dielectric strength: $\geq 250\text{VAC}/1\text{min}$

选型表

CSQC-D09 -10 25 F - 045 H L - I
 ① ② ③ ④ ⑤ ⑥ ⑦ ⑧

序号	说明	序号	说明
① 产品系列 Model	CSQC-A01, ..., CSQC-B01, ..., CSQC-C01, ..., CSQC-D01, ..., CSQC-E01, ..., CSQC-F01, ..., CSQC-G01, ...	⑤ 产品高度 Height	043=4.3mm, 045=4.5mm, 050=5.0mm, ..., 095=9.5mm (H)无高度可选默认为空 The default is empty when the (H) is no optional
② 产品寿命 Service Life	05=50000Times, 10=100000Times, 20=200000Times, 50=500000Times, A1=1000000Times, ...	⑥ 焊接方式 welding method	H=自动焊接 H=Automatic soldering A=手动焊接 A=Hand soldering
③ 操作力 Operating Force	10=100gf, 13=130gf, 16=160gf, 25=250gf, 30=300gf, 35=350gf, 40=400gf, 50=500gf	⑦ 环保类别 Environmental certificate	E=REACH, L=ROHS, F=W/lead
④ 盐雾测试 Cyclic Corrosion Test	无要求为空 No requirement is empty B=24小时盐雾测试 B=24H CCT, C=48小时盐雾测试 C=48H CCT, F=72小时盐雾测试 F=72H CCT, S=96小时盐雾测试 S=96H CCT	⑧ 包装方式 packing method	P=卷装 P=By Rolling I=袋装 I=In polybag B=盒装 B=In box

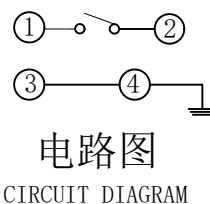

电路图

CIRCUIT DIAGRAM

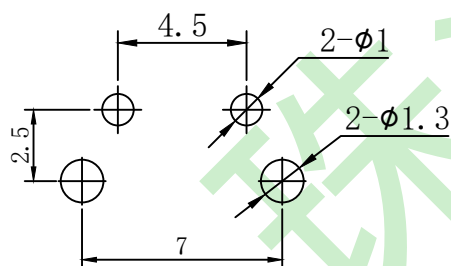

PCB焊接图

PCB. WELDING DRAWING

E	按钮	PPA	1	黑色	未注公差			单位	比例	Design Units	SIZE	页码	
D	盖板	铁	1	镀铜锡	$X.^\circ \pm 3^\circ$	$X.X^\circ \pm 0.5^\circ$	MM Only	_____	METRIC	A4			
C	弹片	不锈钢	1	镀银	$\geq 0-2 <$	$\geq 2-5 <$	≥ 5	角度	材料	品名	轻触开关 (TACTILE SWITCH)		
B	本体	PPA	1	黑色	± 0.15	± 0.25	± 0.35	$\pm 0.5^\circ$	见图解	Part No	CSQC-D09		
A	卡件	黄铜	1	镀银	制作	审核	批准	珠海诚思科技有限公司 ZhuHai ChengSi Technology Co., Ltd					
项目	名称	材质	数量	表面处理/颜色									
ITEM	DESCRIPTION	MATERIAL	QTY	FINISH/COLOR									