

免费拿样，联系电话/微信：18666128282

REV	DESCRIPTION	DATE
A/0	原始版本	
A/1	修订版本	

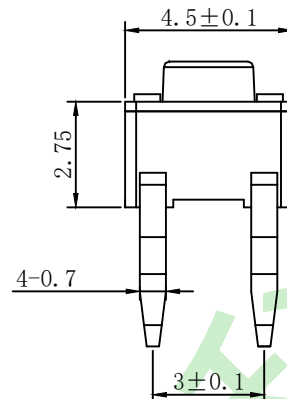
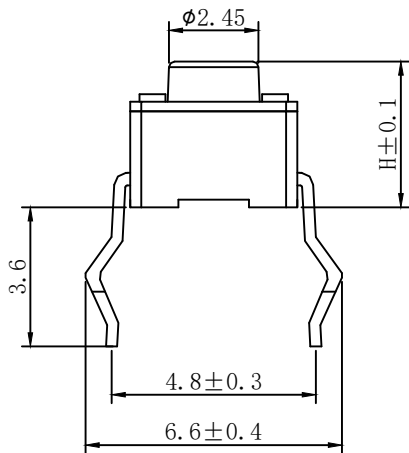
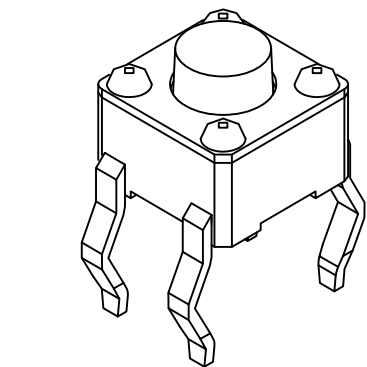

**规格参数:**

额定电流 Rate current: 50mA

额定电压 Rate voltage: DC 12V

接触电阻 Contact resistance:  $\leq 100m\Omega$

操作力 Operating force: 250±40gf(可选)

行程 Travel: 0.2±0.1mm

绝缘电阻 Insulated resistance:  $\geq 100M\Omega$

介电强度 Dielectric strength:  $\geq 250VAC/1min$

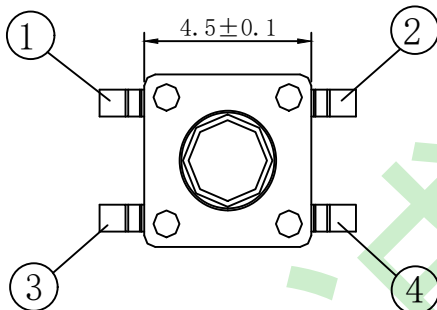
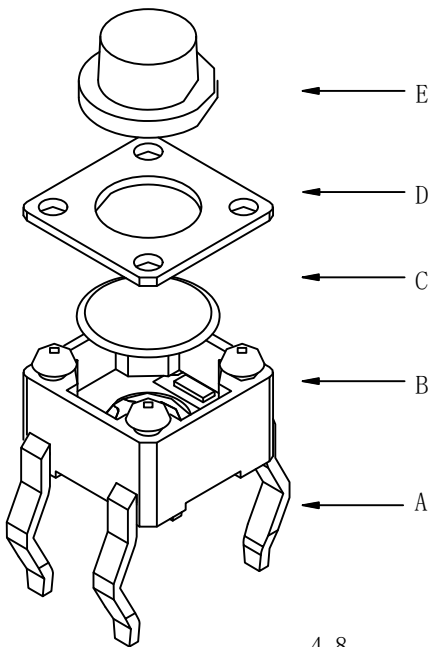

H	
3.5	3.8
4.0	4.5
5.0	5.5
...	10.0

**选型表**

CSQC-C16 -10 25 F - 035 H L - P

① ② ③ ④ ⑤ ⑥ ⑦ ⑧

序号	说明	序号	说明
①产品系列 Model	CSQC-A01, ..., CSQC-B01, ..., CSQC-C01, ..., CSQC-D01, ..., CSQC-E01, ..., CSQC-F01, ..., CSQC-G01, ...	⑤产品高度 Height	035=3.5mm, 038=3.8mm, 040=4.0mm, ..., 100=10.0mm (H) 无高度可选默认为空 The default is empty when the (H) is no optional
②产品寿命 Service Life	05=50000Times, 10=100000Times, 20=200000Times, 50=500000Times, A1=1000000Times, ...	⑥焊接方式 welding method	H=自动焊接 H=Automatic soldering A=手动焊接 A=Hand soldering
③操作力 Operating Force	10=100gf, 13=130gf, 16=160gf, 25=250gf, 30=300gf, 35=350gf, 40=400gf, 50=500gf	⑦环保类别 Environmental certificate	E=REACH, L=ROHS, F=W/lead
④盐雾测试 Cyclic Corrosion Test	无要求为空 No requirement is empty B=24小时盐雾测试 B=24H CCT, C=48小时盐雾测试 C=48H CCT, F=72小时盐雾测试 F=72H CCT, S=96小时盐雾测试 S=96H CCT	⑧包装方式 packing method	P=卷装 P=By Rolling I=袋装 I=In polybag B=盒装 B=In box

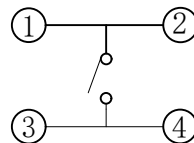

**电路图**

CIRCUIT DIAGRAM

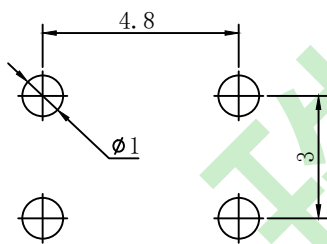

**PCB焊接图**

PCB. WELDING DRAWING

E	按钮	PPA	1	黑色	未注公差			单位	比例	Design Units	SIZE	页码	
D	盖板	铁	1	镀铜锡	$X.^\circ \pm 3^\circ$	$X.X^\circ \pm 0.5^\circ$	MM Only	_____	METRIC	A4			
C	弹片	不锈钢	1	镀银	$\geq 0-2$	$\geq 2-5$	$\geq 5-10$	角度	材料	品名	轻触开关 (TACTILE SWITCH)		
B	本体	PPA	1	黑色	$\pm 0.15$	$\pm 0.25$	$\pm 0.3$	$\pm 0.5^\circ$	见图解	Part No	CSQC-C16		
A	卡件	黄铜	1	镀银	制作	审核	批准	珠海诚思科技有限公司					
项目	名称	材质	数量	表面处理/颜色	ZhuHai ChengSi Technology Co., Ltd								
ITEM	DESCRIPTION	MATERIAL	QTY	FINISH/COLOR									